



## DUPLEX TANK MOUNTED "X" SERIES MEDICAL AIR SYSTEMS 1 THROUGH 5 HP

The EMSE CORPORATION continuous duty Medical Air Plant is a tank mounted, completely packaged NFPA 99 and NEC compliant system featuring oil-less reciprocating air compressors, U.L. listed control cabinet, ASME receiver, and all the accessories to meet and exceed the current code requirements.

All components are piped and wired to single-point service connections. The only field connections are air intake, air discharge and power at the control panel. All interconnecting piping and wiring is complete and operationally tested prior to shipment. Liquid tight conduit, fittings and junction boxes are provided for control and power wiring.

The medical air compressors are rotary, oil-less reciprocating, air-cooled design. Connecting rod and bearings are packed and sealed for life. **No oil is used in operation of the compressors. The discharge air is 100% oil-free.** Cooling is provided by a radial fan with shroud.

Compressors are V-belt driven by 3 phase, 60 cycle, 1750 RPM, NEMA design B motors. Slide bases for belt tension adjustment and totally enclosed OSHA approved belt guards are provided.

The system includes a corrosion resistant receiver of ASME construction rated for 200 PSI MWP service. The tank is equipped with a pressure gauge, safety relief valve, 3 way by-pass, gauge glass and electronic tank drain with manual override.

Also included are compressor discharge check valves, safety relief valves, intake and discharge flexible connectors, solenoid unloaders, isolation valves, high discharge temperature shut-down switches, pressure switches and a shut-off cock for gauge and switches.

The system includes a UL listed control panel in a NEMA 12 enclosure. The panel includes the following for **each** pump: externally operable circuit breaker with a door interlock, control circuit transformer with fused primary and secondary coils, H-O-A switch, run light, hour meter and magnetic starter with 3 leg overload protection and reset switch. The panel is equipped with a multiple position selector switch for selection of normal operation (automatic alternation) or manual selection of lead and lag pumps if one is taken out of service due to scheduled maintenance.

Local audible and visual alarms are provided per NFPA 99 for compressor thermal malfunction and "Backup in use". The alarms include indicating lights and a horn. The thermal malfunction shut-down is provided with a manual



reset. The audible alarm can be cancelled with the "Silence" button. The visual alarm remains energized until the problem is corrected. Each alarm function includes a set of dry contacts for connection to the master alarm. All control and alarm functions remain energized while any compressor in the system is electrically on-line. Disconnect switches for air dryers are included. Field adjustable control switches are pre-set to operate the lead compressor between 90 PSIG and 120 PSIG. The lag compressor will automatically start at 85 PSIG if the lead compressor fails to operate. The Medical Air Plant is guaranteed by the manufacturer for a period of 12 months from the date of start-up or 18 months from the date of shipment (whichever comes first) against defects in design, materials, or construction. In addition, the compressors are guaranteed for 36 months from the date of shipment.

### Optional System Accessories

(only checked options will be supplied)

- "Dura-coat" rust protection receiver lining
- Galvanized receiver
- Air-cooled aftercoolers
- Dual medical air treatment system with refrigerated air dryers

**DUPLEX TANK MOUNTED  
"X" SERIES MEDICAL AIR SYSTEMS  
1 THROUGH 5 HP  
LAYOUT AND PERFORMANCE TABLE**

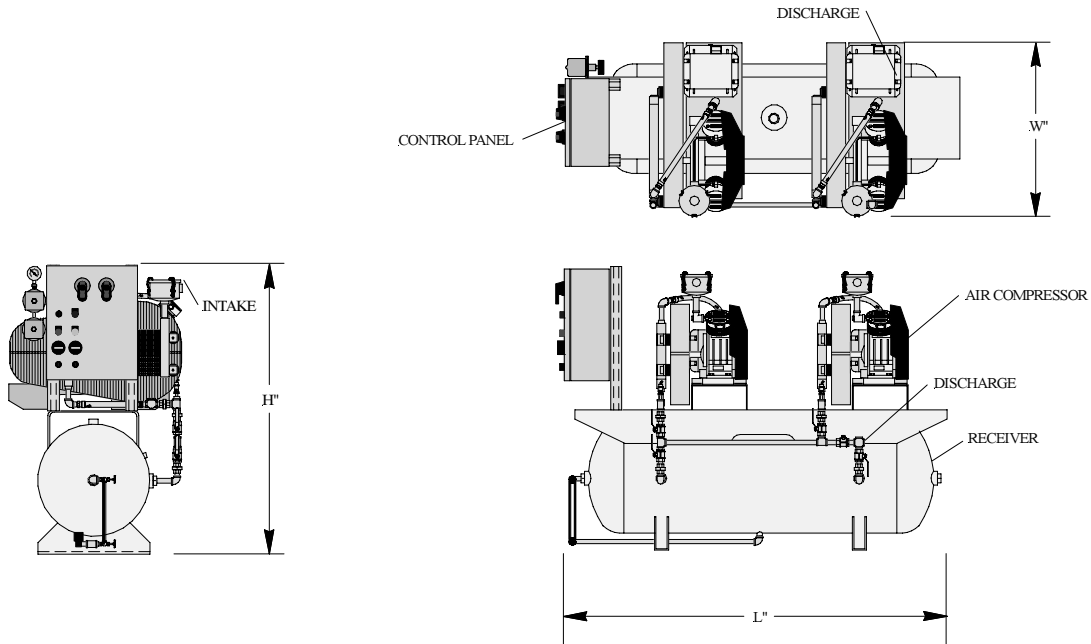

System Model Number	Horsepower		Capacity SCFM (Each Pump)		Disch. Conn.	Tank (Gal.)	Dimensions, In.			Weight Lbs.
	Each	Total	50 PSIG	100 PSIG			L	W	H	
3DOX1T80	1	2	4.7	3.6	1/2"	80	70	27	52	550
3DOX1.5T80	1.5	3	6.7	5.2	1/2"	80	70	27	52	600
3DOX2T80	2	4	9.2	7.6	1/2"	80	70	33	52	610
3DOX2T120	2	4	9.2	7.6	1/2"	120	74	33	58	750
3DOX3T80	3	6	12.1	10.1	1/2"	80	70	33	52	690
3DOX3T120	3	6	12.1	10.1	1/2"	120	74	33	58	870
3DOX5T80	5	10	20.9	17.9	1/2"	80	70	34	52	910
3DOX5T120	5	10	20.9	17.9	1/2"	120	74	34	58	1090

**Note:** Maximum ambient temperature: 100°F. For higher ambient temperatures consult factory.

**Power Requirements:**

(Two) \_\_\_\_\_ HP Motors, 3 Phase 60 Hertz     208 v     230 v     460 v